



# Corrosion Resistant Catalog

**Your Premium  
Bearing Alternative!**

3rd Edition







## KML Platinum Series

KML Bearing USA proudly presents new Food Safety Modernization Act-compliant sanitary designs to its Platinum Series Corrosion Resistant Mounted Bearing Units.

### Stainless Steel Stand-Out Units

- Rear seals are flush-press-fit into a counter bore in the rear face.
- Rear seals feature TC double lip design with garter spring shaft compression.
- Caps are compression fit with locking tabs to withstand high pressure wash-down without dislodging.
- Cap seals for the through-shaft design feature correct diameter double-lip TC type seals.
- Seams are reduced to self-draining cylindrical posts.
- Full 1/2" cleaning corridor adjacent to the bearing mounting area.
- Caps and rear seals are available for the correct shaft size eliminating unwanted cavities in the bearing housing.

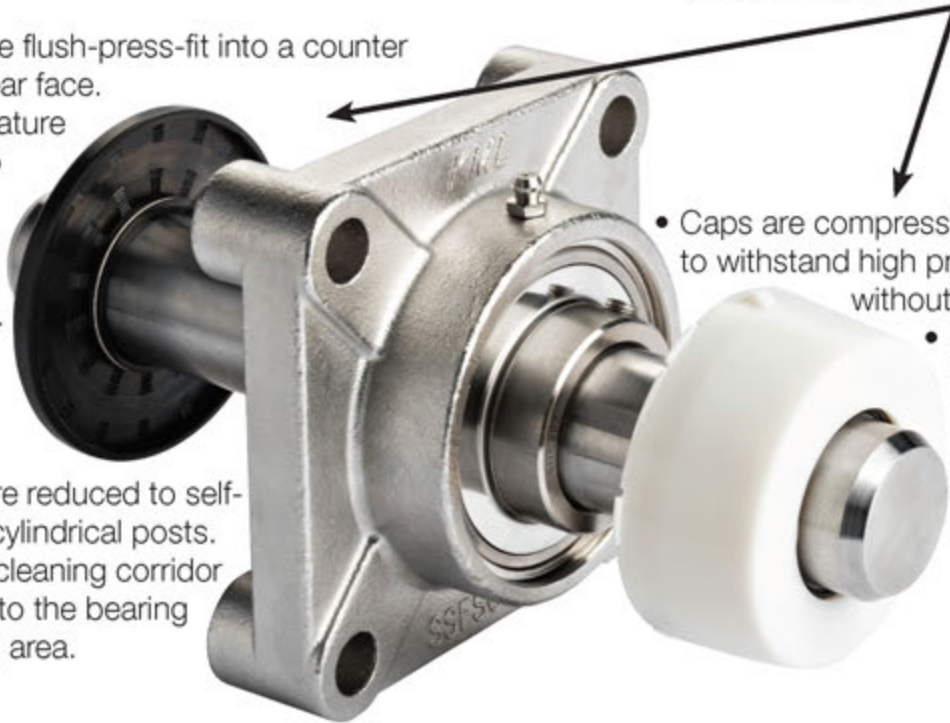

### K-Poly™ Solid Polymer Lubricant

Faced with the new challenges presented by FSMA regulations, **KML K-Poly™ Solid Polymer Lubricants** provide the food processing industry with a true 'Lube-for-Life' solution! Whether Food Service Grade H1 lubricant or an industrial grade formula, **KML K-Poly™** doesn't drip past the seals.



Not only do **KML K-Poly™ Solid Polymer Lubricants** provide a food-safe lubrication, but they also reduce costs by eliminating relubrication and maintenance downtime. The micro-porous polymer releases food grade synthetic oils as the bearing warms during operation. Then, once the bearing has stopped rotating and cools, the oil is reabsorbed into the polymeric capillaries.



# Corrosion Resistant Products

<b><i>KML Stand-Out Mounted Bearings</i></b> .....	3
<b><i>KML Poly-Guard IP69K Sealing System</i></b> .....	4
<b><i>The KML IP69K Test Stand Parameters</i></b> .....	5
<b>STAINLESS STEEL STAND-OUT UNITS</b>	
<b><i>Stainless Steel Four Bolt Stand-Out Flange, SSUCFSO</i></b> .....	6
<b><i>Stainless Steel Stand-Out Flange Bracket, SSUCFBSO</i></b> .....	7
<b><i>Stainless Steel Two Bolt Stand-Out Flange, SSUCFLSO</i></b> .....	8
<b><i>Stainless Steel Tap Base Stand-Out Pillow Block, SSUCPASO</i></b> .....	9
<b>POLY-GUARD IP69K SEAL KITS</b>	
<b><i>For Stainless Steel Stand-Out Flange Units</i></b> .....	10 - 11
<b><i>For Stainless Steel Stand-Out Pillow Block Units</i></b> .....	12 - 13
<b>STAINLESS STEEL MOUNTED UNITS</b>	
<b><i>Stainless Steel Four Bolt Flange, SSUCF</i></b> .....	14
<b><i>Stainless Steel Flange Bracket, SSUCFB</i></b> .....	15
<b><i>Stainless Steel Two Bolt Flange, SSUCFL</i></b> .....	16
<b><i>Stainless Steel Pillow Block, SSUCP</i></b> .....	17
<b><i>Stainless Steel Tap Base Pillow Block, SSUCPA</i></b> .....	18
<b><i>Stainless Steel Take-Up Unit, SSUCT</i></b> .....	19
<b>THERMOPLASTIC MOUNTED UNITS</b>	
<b><i>Thermoplastic Four Bolt Flange, SSUCTPF</i></b> .....	20
<b><i>Thermoplastic Flange Bracket, SSUCTPFB</i></b> .....	21
<b><i>Thermoplastic Two Bolt Flange, SSUCTPFL</i></b> .....	22
<b><i>Thermoplastic Pillow Block, SSUCTPP</i></b> .....	23
<b><i>Thermoplastic Tap Base Pillow Block, SSUCTPTB</i></b> .....	24
<b><i>Thermoplastic Caps</i></b> .....	25
<b><i>All Stainless Steel Insert Bearings</i></b> .....	26 - 27
<b><i>Triple Lip Seal, Black Oxide Insert Bearings</i></b> .....	28 - 29
<b><i>440C Stainless Steel Ball Bearings</i></b> .....	30 - 31
<b><i>KML K-Poly™ High Performance Solid Polymer Lubricant</i></b> .....	32 - 34





# Corrosion Resistant Products

KML's Corrosion Resistant Mounted Bearing Unit Part Numbering System is a series of formats that in combination identify a specific part number. These formats identify the corrosion resistant mounted bearing units type, series, housing style, shaft size and additional part-specific information.

### Corrosion Resistant Housings

- SSP:** Stainless Steel Pillow Block
- TPP:** Thermoplastic Pillow Block
- SSPA:** Stainless Steel Tap Base Pillow Block - Inch
- SSPASO:** Stainless Steel Tap Base Stand Out Pillow Block - Inch
- TPTB:** Thermoplastic Tap Base Pillow Block - Inch
- SSFL:** Stainless Steel 2-Bolt Diamond Flange
- SSFLSO:** Stainless Steel 2-Bolt Stand Out Diamond Flange
- SSPFL:** Pressed Stainless Steel 2-Bolt Flange Set
- TPFL:** Thermoplastic 2-Bolt Diamond Flange
- SSFB:** Stainless Steel 3-Bolt Offset Flange - Inch
- SSFBSO:** Stainless Steel 3-Bolt Stand Out Offset Flange - Inch
- TPFB:** Thermoplastic 3-Bolt Offset Flange - Inch
- SSF:** Stainless Steel 4-Bolt Square Flange
- SSFSO:** Stainless Steel 4-Bolt Stand Out Square Flange
- TPF:** Thermoplastic 4-Bolt Square Flange
- SST:** Stainless Steel Take-up - Wide Slot
- TPT:** Thermoplastic Take-up - Wide Slot

### Prefix Markings

**SS:** Stainless Steel

### Shaft Size Dimensions

**Inch Dimensions:** In 16ths of an inch  
(Example: SSUC205-16 = 1")  
**Metric Dimensions:** Blank  
(Example: SSUC204 = 20mm)



### Insert Bearings

- SSUC:** Stainless Steel Wide Inner Ring, Dual Set Screw
- SSHC:** Stainless Steel Wide Inner Ring, Eccentric Locking Collar
- SSSB:** Stainless Steel Narrow Inner Ring, Dual Set Screw

### Series Designation

Light/Normal Duty  
201-211

### Suffix:

Indicates additional features applicable to the bearing insert or bearing unit

**NF:** No grease fitting



# **KML** **STAND-OUT™** MOUNTED BEARINGS



***Their cleanability is unmatched by previous mounted bearing designs.***

KML Stand-Out Style Bearing Housings provide the next level of sanitary performance in High Moisture Application Bearing Systems. This exciting next generation design provides the following Features and Benefits:

- ✓ Bacteria harborage sites and edge seams are eliminated
- ✓ Seams are reduced to self-draining cylindrical posts
- ✓ Full 1/2" cleaning corridor adjacent to the bearing mounting area
- ✓ The bearing operating area is moved further away from the critical food contact product area
- ✓ Fabrication and welding operations of previously used clearance spacers are eliminated saving time and money
- ✓ Caps and rear seals are available for the correct shaft size eliminating unwanted cavities in the bearing housing
- ✓ Bearing housings, caps and rear seals are watertight

***They are outstanding!***



# **KML** **Poly-Guard IP69K Sealing System**



## ***Performance is unmatched by previous designs***

- ✓ Standard front caps are fully enclosed
  - ✓ Open front caps are available for through shaft applications
  - ✓ Open caps fit both inch and metric applications with correct diameter shaft seals
  - ✓ Caps are compression fit with locking tabs to withstand high pressure wash-down without dislodging
  - ✓ Cap seals for the through-shaft design feature correct double-lip TC type seals
- 
- ✓ Rear seals are flush-press-fit into a counter bore in the rear face
  - ✓ Rear seals feature TC double lip design with garter spring shaft compression
  - ✓ Bearing cavity and installation slot are completely sealed eliminating harborage areas
  - ✓ Wide inner ring bearing inserts are utilized for optimum shaft engagement while being hermetically sealed within the mounting cavity
  - ✓ Stand-out housing mount allows cleaning around the housing



***KML Poly-Guard Sealing System provides the next level of sanitary enclosure in high moisture bearing applications.***

***This exciting next generation design provides outstanding protection that will increase bearing life expectancy.***



The IP69K rating provides protection against the ingress of dust and high temperature, high pressure water; thereby, making products with this certification ideal for use in conditions where equipment must be cleaned and sanitized.

## **What is IP69K?**

In industries such as food processing, where hygienic design and sanitizing are paramount, equipment must be able to withstand rigorous high pressure, high temperature wash-down procedures.

## **The KML IP69K Test Stand Parameters**

- ✓ 1,500 psi nozzle pressure
- ✓ Four application wands at IP69K specified angular locations
- ✓ Product located 10-15cm from the tip of the nozzle
- ✓ 360° product table rotation @ 5 RPM during exposure
- ✓ 30 seconds exposure at each nozzle location constitutes a complete test cycle
- ✓ Product to be fitted with closed front cap and rear seal with shaft installed for a complete test cycle
- ✓ Product to be fitted with an open front cap and rear seal with shaft installed for a complete test cycle



This is the answer both OEMs and Consumer Goods Companies (CPGs) need in this fast-paced, post Food Safety and Modernization Act (FSMA) environment that requires forward-looking solutions. The KML Poly-Guard Sealing System encapsulates the bearing protecting it from the high velocity chemical wash-down solutions. This helps prevent corrosion of the critical bearing surfaces and also reduces the chemical damage and embrittlement to critical sealing surfaces.



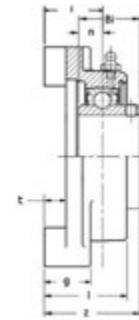
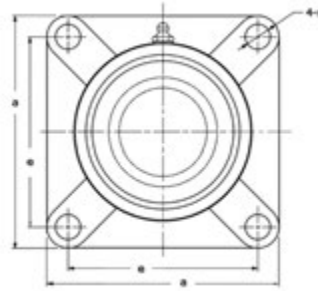

# STAINLESS STEEL FOUR BOLT STAND-OUT FLANGE

## Stainless Steel Insert

### SSUCFSO 200 Series

- ✓ Solid Base
- ✓ Normal Duty
- ✓ Set Screw Locking

Unit No.	Shaft Dia. Inch	Inch Parts - Dimensions (inch)										Bolt Size	Bearing No.	Housing No.	Weight lbs
		a	e	g	l	s	t	z	i	Bi	n				
SSUCFSO205-14	7/8	3-3/4	2-3/4	1-11/32	1-7/8	7/16	1/2	2-5/32	1-3/8	1.343	0.563	3/8	SSUC205-14	SSFSO205	3.03
SSUCFSO205-15	15/16												SSUC205-15		
SSUCFSO205-16	1												SSUC205-16		
SSUCFSO206-17	1-1/16	4-1/4	3-1/4	1-1/4	1-31/32	1/2	1/2	2-5/16	1-7/16	1.500	0.625	3/8	SSUC206-17	SSFSO206	3.60
SSUCFSO206-18	1-1/8												SSUC206-18		
SSUCFSO206-19	1-3/16												SSUC206-19		
SSUCFSO206-20	1-1/4S												SSUC206-20		
SSUCFSO207-20	1-1/4	4-5/8	3-5/8	1-7/32	2-1/16	1/2	1/2	2-1/2	1-1/2	1.689	0.689	7/16	SSUC207-20	SSFSO207	4.32
SSUCFSO207-21	1-5/16												SSUC207-21		
SSUCFSO207-22	1-3/8												SSUC207-22		
SSUCFSO207-23	1-7/16												SSUC207-23		
SSUCFSO208-24	1-1/2	5-1/8	4	1-7/32	2-1/8	9/16	1/2	2-3/4	1-9/16	1.937	0.750	1/2	SSUC208-24	SSFSO208	5.47
Unit No.	Shaft Dia. mm	Metric Parts - Dimensions (mm)										Bolt Size	Bearing No.	Housing No.	Weight kg
		a	e	g	l	s	t	z	i	Bi	n				
SSUCFSO205	25	95.3	69.9	34.1	47.6	11.1	12.7	54.8	34.9	34.1	14.3	M10	SSUC205	SSFSO205	1.38
SSUCFSO206	30	108.0	82.6	31.7	50.0	12.7	12.7	58.7	36.5	38.1	15.9	M10	SSUC206	SSFSO206	1.63
SSUCFSO207	35	117.5	92.1	31.0	52.4	12.7	12.7	63.5	38.1	42.9	17.5	M10	SSUC207	SSFSO207	1.96
SSUCFSO208	40	130.2	101.6	31.0	54.0	14.3	12.7	69.8	39.7	49.2	19.0	M12	SSUC208	SSFSO208	2.48





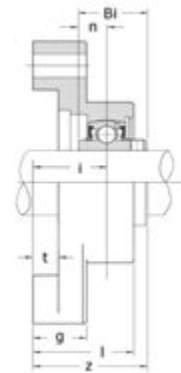
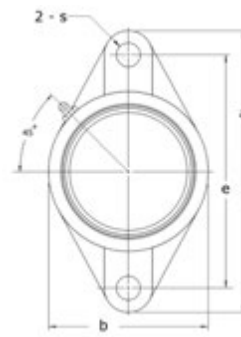
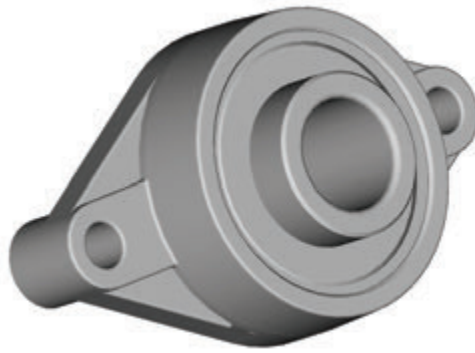

# STAINLESS STEEL TWO BOLT STAND-OUT FLANGE

## Stainless Steel Insert

### SSUCFLSO 200 Series

- ✓ Solid Base
- ✓ Normal Duty
- ✓ Set Screw Locking

Unit No.	Shaft Dia. Inch	Inch Parts - Dimensions (inch)											Bolt Size	Bearing No.	Housing No.	Weight lbs	
		a	e	b	g	l	s	t	z	i	Bi	n					
SSUCFLSO201-8	1/2														SSUC201-8		
SSUCFLSO202-10	5/8	4-13/32	3-17/32	2-3/8	31/32	1-25/32	25/64	1/2	2-1/32	1-5/16	1.219	0.500	3/8	SSUC202-10	SSFLSO204	1.25	
SSUCFLSO204-12	3/4												SSUC204-12				
SSUCFLSO205-14	7/8													SSUC205-14	SSFLSO205	1.80	
SSUCFLSO205-15	15/16	4-15/16	3-57/64	2-11/16	1-9/32	1-7/8	15/32	1/2	2-5/32	1-3/8	1.343	0.563	3/8	SSUC205-15			
SSUCFLSO205-16	1													SSUC205-16			
SSUCFLSO206-17	1-1/16													SSUC206-17	SSFLSO206	2.19	
SSUCFLSO206-18	1-1/8	5-9/16	4-19/32	3-5/32	1	1-31/32	15/32	1/2	2-5/16	1-7/16	1.500	0.625	3/8	SSUC206-18			
SSUCFLSO206-19	1-3/16													SSUC206-19			
SSUCFLSO206-20	1-1/4S													SSUC206-20			
SSUCFLSO207-20	1-1/4													SSUC207-20	SSFLSO207	3.04	
SSUCFLSO207-21	1-5/16	6-1/8	5-1/8	3-9/16	1-1/16	2-1/16	1/2	1/2	2-1/2	1-1/2	1.689	0.689	7/16	SSUC207-21			
SSUCFLSO207-22	1-3/8													SSUC207-22			
SSUCFLSO207-23	1-7/16													SSUC207-23			
Unit No.	Shaft Dia. mm	Metric Parts - Dimensions (mm)											Bolt Size	Bearing No.	Housing No.	Weight kg	
a	e	b	g	l	s	t	z	i	Bi	n							
SSUCFLSO204	20	111.9	89.7	60.3	24.6	45.2	9.9	12.7	51.6	33.3	31.0	12.7	M8	SSUC204	SSFLSO204	0.57	
SSUCFLSO205	25	125.4	98.8	68.3	32.5	47.6	11.9	12.7	54.8	34.9	34.1	14.3	M10	SSUC205	SSFLSO205	0.82	
SSUCFLSO206	30	141.3	116.7	80.2	25.4	50.0	11.9	12.7	58.7	36.5	38.1	15.9	M10	SSUC206	SSFLSO206	1.00	
SSUCFLSO207	35	155.6	130.2	90.5	27.0	52.4	12.7	12.7	63.5	38.1	42.9	17.5	M12	SSUC207	SSFLSO207	1.38	

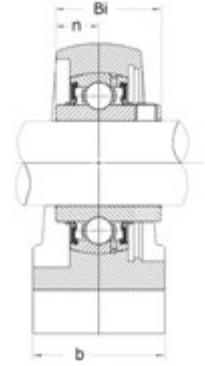
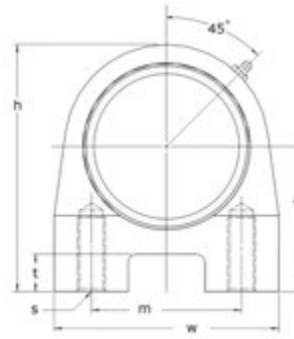
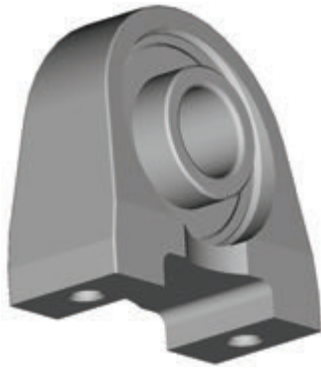

**STAINLESS STEEL TAP BASE STAND-OUT PILLOW BLOCK**  
**Stainless Steel Insert**  
**SSUCPASO 200 Series**

- ✓ Normal Duty
- ✓ Set Screw Locking
- ✓ Inch Bolt Holes

Unit No.	Shaft Dia. Inch	Inch Parts - Dimensions (inch)									Bearing No.	Housing No.	Weight lbs
		a	b	h	m	w	s	t	Bi	n			
SSUCPASO205-14	7/8	1-15/16	1-1/2	3-5/16	2	3	3/8 - 16	1/2	1.343	0.563	SSUC205-14	SSPASO205	1.93
SSUCPASO205-15	15/16										SSUC205-15		
SSUCPASO205-16	1										SSUC205-16		
SSUCPASO207-20	1-1/4	2-3/8	1-7/8	4-1/4	3-1/4	4-1/4	1/2 - 13	1/2	1.689	0.689	SSUC207-20	SSPASO207	4.06
SSUCPASO207-21	1-5/16										SSUC207-21		
SSUCPASO207-22	1-3/8										SSUC207-22		
SSUCPASO207-23	1-7/16										SSUC207-23		
Unit No.	Shaft Dia. mm	Metric Parts - Dimensions (mm)									Bearing No.	Housing No.	Weight kg
		a	b	h	m	w	s	t	Bi	n			
SSUCPASO205	25	49.2	38.1	84.1	50.8	76.2	3/8 - 16	12.7	34.1	14.3	SSUC205	SSPASO205	0.88
SSUCPASO207	35	60.3	47.6	108.0	82.6	108.0	1/2 - 13	12.7	42.9	17.5	SSUC207	SSPASO207	1.84





## POLY-GUARD IP69K SEAL KITS for KML Stainless Steel Stand-Out Flange Units End Shaft Application with SSFSO, SSFLSO, SSFBSO

Seal Kit Part Number	Shaft Dia. Inch	Inch Shaft Dimension			
		Shaft Type	Closed Cap - 1 pc.	Back Seal - 1 pc.	V-Ring - 1 pc.
FIP69K-12 CC	3/4	end shaft	CC204 Closed Cap	BS204-12	VS020 20mm V-ring
FIP69K-16 CC	1	end shaft	CC205 Closed Cap	BS205-16	VS025 25mm V-ring
FIP69K-19 CC	1-3/16	end shaft	CC206 Closed Cap	BS206-19	VS030 30mm V-ring
FIP69K-20S CC	1-1/4S			BS206-20	VS032 32mm V-ring
FIP69K-20 CC	1-1/4	end shaft	CC207 Closed Cap	BS207-20	VS032 32mm V-ring
FIP69K-22 CC	1-3/8			BS207-22	VS035 35mm V-ring
FIP69K-23 CC	1-7/16			BS207-23	VS038 38mm V-ring
FIP69K-24 CC	1-1/2	end shaft	CC208 Closed Cap	BS208-24	VS038 38mm V-ring
Seal Kit Part Number	Shaft Dia. mm	Metric Shaft Dimension			
		Shaft Type	Closed Cap - 1 pc.	Back Seal - 1 pc.	V-Ring - 1 pc.
FIP69K-20M CC	20	end shaft	CC204 Closed Cap	BS204	VS020 20mm V-ring
FIP69K-25M CC	25	end shaft	CC205 Closed Cap	BS205	VS025 25mm V-ring
FIP69K-30M CC	30	end shaft	CC206 Closed Cap	BS206	VS030 30mm V-ring
FIP69K-35M CC	35	end shaft	CC207 Closed Cap	BS207	VS035 35mm V-ring
FIP69K-40M CC	40	end shaft	CC208 Closed Cap	BS208	VS040 40mm V-ring



## POLY-GUARD IP69K SEAL KITS for KML Stainless Steel Stand-Out Flange Units Through Shaft Application with SSFSO, SSFLSO, SSFBSO

Seal Kit Part Number	Shaft Dia. Inch	Inch Shaft Dimension			
		Shaft Type	Open Cap - 1 pc.	Back Seal - 1 pc.	V-Rings - 2 pcs.
FIP69K-12 OC	3/4	through shaft	OC204 Open Cap with seal	BS204-12	VS020 20mm V-rings
FIP69K-16 OC	1	through shaft	OC205 Open Cap with seal	BS205-16	VS025 25mm V-rings
FIP69K-19 OC	1-3/16	through shaft	OC206 Open Cap with seal	BS206-19	VS030 30mm V-rings
FIP69K-20S OC	1-1/4S			BS206-20	VS032 32mm V-rings
FIP69K-20 OC	1-1/4			BS207-20	VS032 32mm V-rings
FIP69K-22 OC	1-3/8			BS207-22	VS035 35mm V-rings
FIP69K-23 OC	1-7/16			BS207-23	VS038 38mm V-rings
FIP69K-24 OC	1-1/2	through shaft	OC208 Open Cap with seal	BS208-24	VS038 38mm V-rings
Seal Kit Part Number	Shaft Dia. mm	Metric Shaft Dimension			
		Shaft Type	Open Cap - 1 pc.	Back Seal - 1 pc.	V-Rings - 2 pcs.
FIP69K-20M OC	20	through shaft	OC204 Open Cap with seal	BS204	VS020 20mm V-rings
FIP69K-25M OC	25	through shaft	OC205 Open Cap with seal	BS205	VS025 25mm V-rings
FIP69K-30M OC	30	through shaft	OC206 Open Cap with seal	BS206	VS030 30mm V-rings
FIP69K-35M OC	35	through shaft	OC207 Open Cap with seal	BS207	VS035 35mm V-rings
FIP69K-40M OC	40	through shaft	OC208 Open Cap with seal	BS208	VS040 40mm V-rings



## POLY-GUARD IP69K SEAL KITS for KML Stainless Steel Stand-Out Pillow Block Units End Shaft Application with SSPASO

Seal Kit Part Number	Shaft Dia. Inch	Inch Shaft Dimension			
		Shaft Type	Closed Cap - 1 pc.	Back Seal - 1 pc.	V-Ring - 1 pc.
PIP69K-16 CC	1	end shaft	CC205 Closed Cap	BSE205-16	VS025 25mm V-ring
PIP69K-20 CC	1-1/4	end shaft	CC207 Closed Cap	BSE207-20	VS032 32mm V-ring
PIP69K-22 CC	1-3/8			BSE207-22	VS035 35mm V-ring
PIP69K-23 CC	1-7/16			BSE207-23	VS038 38mm V-ring
Seal Kit Part Number	Shaft Dia. mm	Metric Shaft Dimension			
		Shaft Type	Closed Cap - 1 pc.	Back Seal - 1 pc.	V-Ring - 1 pc.
PIP69K-25M CC	25	end shaft	CC205 Closed Cap	BSE205	VS025 25mm V-ring
PIP69K-35M CC	35	end shaft	CC207 Closed Cap	BSE207	VS035 35mm V-ring





**POLY-GUARD IP69K SEAL KITS**  
**for KML Stainless Steel Stand-Out Pillow Block Units**  
**Through Shaft Application with SSPASO**

Seal Kit Part Number	Shaft Dia. Inch	Inch Shaft Dimension			
		Shaft Type	Open Cap - 1 pc.	Back Seal - 1 pc.	V-Rings - 2 pcs.
PIP69K-16 OC	1	through shaft	OC205 Open Cap with seal	BSE205-16	VS025 25mm V-rings
PIP69K-20 OC	1-1/4	through shaft	OC207 Open Cap with seal	BSE207-20	VS032 32mm V-rings
PIP69K-22 OC	1-3/8			BSE207-22	VS035 35mm V-rings
PIP69K-23 OC	1-7/16			BSE207-23	VS038 38mm V-rings
Seal Kit Part Number	Shaft Dia. mm	Metric Shaft Dimension			
		Shaft Type	Open Cap - 1 pc.	Back Seal - 1 pc.	V-Rings - 2 pcs.
PIP69K-25M OC	25	through shaft	OC205 Open Cap with seal	BSE205	VS025 25mm V-rings
PIP69K-35M OC	35	through shaft	OC207 Open Cap with seal	BSE207	VS035 35mm V-rings

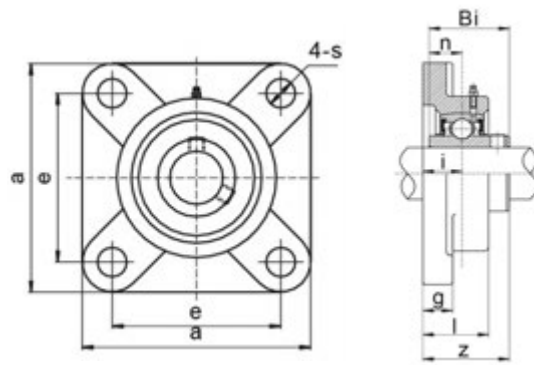

# STAINLESS STEEL FOUR BOLT FLANGE

## Stainless Steel Insert

### SSUCF 200 Series

- ✓ Solid Base
- ✓ Normal Duty
- ✓ Set Screw Locking

Unit No.	Shaft Dia. Inch	Inch Parts - Dimensions (inch)									Bolt Size	Bearing No.	Housing No.	Weight lbs
		a	e	g	l	s	z	i	Bi	n				
SSUCF201-8	1/2											SSUC201-8		
SSUCF202-10	5/8	3-3/8	2-1/2	15/32	1	7/16	1-5/16	19/32	1.221	0.500	3/8	SSUC202-10	SSF204	1.42
SSUCF204-12	3/4											SSUC204-12		
SSUCF205-14	7/8											SSUC205-14		
SSUCF205-15	15/16	3-3/4	2-3/4	9/16	1-1/16	29/64	1-13/32	5/8	1.343	0.563	3/8	SSUC205-15	SSF205	1.87
SSUCF205-16	1											SSUC205-16		
SSUCF206-17	1-1/16											SSUC206-17		
SSUCF206-18	1-1/8											SSUC206-18		
SSUCF206-19	1-3/16	4-1/4	3-1/4	9/16	1-3/16	33/64	1-37/64	45/64	1.500	0.626	3/8	SSUC206-19	SSF206	2.57
SSUCF206-20	1-1/4S											SSUC206-20		
SSUCF207-20	1-1/4											SSUC207-20		
SSUCF207-21	1-5/16	4-5/8	3-5/8	9/16	1-19/64	33/64	1-3/4	3/4	1.689	0.689	7/16	SSUC207-21	SSF207	3.32
SSUCF207-22	1-3/8											SSUC207-22		
SSUCF207-23	1-7/16											SSUC207-23		
SSUCF208-24	1-1/2	5-1/8	4	9/16	1-27/64	9/16	2-1/64	13/16	1.937	0.748	7/16	SSUC208-24	SSF208	4.44
SSUCF209-26	1-5/8											SSUC209-26		
SSUCF209-27	1-11/16	5-25/64	4-1/8	9/16	1-1/2	5/8	2-3/64	55/64	1.937	0.748	5/8	SSUC209-27	SSF209	4.80
SSUCF209-28	1-3/4											SSUC209-28		
SSUCF210-30	1-7/8											SSUC210-30		
SSUCF210-31	1-15/16	5-5/8	4-3/8	19/32	1-17/32	5/8	2-9/64	55/64	2.032	0.748	5/8	SSUC210-31	SSF210	5.35
SSUCF210-32	2S											SSUC210-32		
SSUCF211-32	2	6-3/8	5-1/8	23/32	1-11/16	43/64	2-5/16	63/64	2.189	0.874	5/8	SSUC211-32	SSF211	8.10
Unit No.	Shaft Dia. mm	Metric Parts - Dimensions (mm)									Bolt Size	Bearing No.	Housing No.	Weight kg
		a	e	g	l	s	z	i	Bi	n				
SSUCF204	20	85.7	63.5	11.9	25.4	11.1	33.3	15.1	31.0	12.7	M8	SSUC204	SSF204	0.65
SSUCF205	25	95.3	69.9	14.3	27.0	11.5	35.7	15.9	34.1	14.3	M8	SSUC205	SSF205	0.85
SSUCF206	30	108.0	82.6	14.3	30.2	13.1	40.1	17.9	38.1	15.9	M8	SSUC206	SSF206	1.17
SSUCF207	35	117.5	92.1	14.3	32.9	13.1	44.5	19.1	42.9	17.5	M10	SSUC207	SSF207	1.51
SSUCF208	40	130.2	101.6	14.3	36.1	14.3	51.2	20.6	49.2	19.0	M10	SSUC208	SSF208	2.02
SSUCF209	45	136.9	104.8	14.3	38.1	15.9	52.0	21.8	49.2	19.0	M16	SSUC209	SSF209	2.18
SSUCF210	50	142.9	111.1	15.1	38.9	15.9	54.4	21.8	51.6	19.0	M16	SSUC210	SSF210	2.43
SSUCF211	55	161.9	130.2	18.3	42.9	17.1	58.7	25.0	55.6	22.2	M16	SSUC211	SSF211	3.68

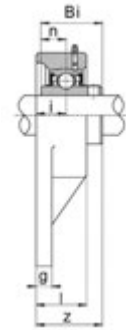
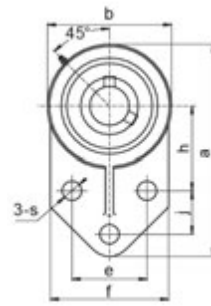

# STAINLESS STEEL FLANGE BRACKET

## Stainless Steel Insert

### SSUCFB 200 Series

- ✓ Solid Base
- ✓ Normal Duty
- ✓ Set Screw Locking

Unit No.	Shaft Dia. Inch	Inch Parts - Dimensions (inch)														Bolt Size	Bearing No.	Housing No.	Weight lbs
		a	h	e	j	g	l	s	b	f	z	i	Bi	n					
SSUCFB201-8	1/2																SSUC201-8	SSFB204	1.28
SSUCFB202-10	5/8	4-1/4	1-11/16	1-1/2	7/8	5/16	1	25/64	2-31/64	2-23/64	1-11/32	5/8	1.220	0.500	5/16	SSUC202-10			
SSUCFB204-12	3/4															SSUC204-12			
SSUCFB205-14	7/8															SSUC205-14	SSFB205	1.63	
SSUCFB205-15	15/16	4-5/8	1-13/16	1-5/8	1-1/8	3/8	1-9/64	25/64	2-3/4	2-33/64	1-29/64	21/32	1.343	0.563	5/16	SSUC205-15			
SSUCFB205-16	1															SSUC205-16			
SSUCFB206-17	1-1/16															SSUC206-17	SSFB206	2.40	
SSUCFB206-18	1-1/8	5-25/64	2-1/16	1-7/8	1-1/4	3/8	1-1/4	25/64	3-17/64	2-3/4	1-5/8	3/4	1.500	0.626	5/16	SSUC206-18			
SSUCFB206-19	1-3/16															SSUC206-19			
SSUCFB206-20	1-1/4S															SSUC206-20			
SSUCFB207-20	1-1/4															SSUC207-20	SSFB207	3.61	
SSUCFB207-21	1-5/16	6-9/64	2-3/8	2	1-1/4	17/32	1-29/64	33/64	3-3/4	3-1/4	1-53/64	13/16	1.689	0.689	3/8	SSUC207-21			
SSUCFB207-22	1-3/8															SSUC207-22			
SSUCFB207-23	1-7/16															SSUC207-23			
SSUCFB208-24	1-1/2	6-29/64	2-23/64	1-31/32	1-39/64	5/8	1-11/32	7/16	3-15/16	3-5/64	2-1/64	13/16	1.937	0.748	3/8	SSUC208-24	SSFB208	5.04	
SSUCFB209-26	1-5/8															SSUC209-26	SSFB209	5.70	
SSUCFB209-27	1-11/16	6-27/32	2-9/16	2-1/8	1-11/16	23/32	1-11/32	7/16	4-11/64	3-5/32	2-1/64	13/16	1.937	0.748	3/8	SSUC209-27			
SSUCFB209-28	1-3/4															SSUC209-28			
SSUCFB210-30	1-7/8															SSUC210-30	SSFB210	6.91	
SSUCFB210-31	1-15/16	7-33/64	2-15/16	2-3/4	1-5/8	1/2	1-1/2	33/64	4-41/64	4-1/64	2-7/64	13/16	2.032	0.748	3/8	SSUC210-31			
SSUCFB210-32	2S															SSUC210-32			
Unit No.	Shaft Dia. mm	Metric Parts - Dimensions (mm)														Bolt Size	Bearing No.	Housing No.	Weight kg
		a	h	e	j	g	l	s	b	f	z	i	Bi	n					
SSUCFB204	20	108.0	42.9	38.1	22.2	7.9	25.4	9.9	63.1	59.9	34.1	15.9	31.0	12.7	M8	SSUC204	SSFB204	0.58	
SSUCFB205	25	117.5	46.0	41.3	28.6	9.5	29.0	9.9	66.9	63.9	36.9	16.7	34.1	14.3	M8	SSUC205	SSFB205	0.74	
SSUCFB206	30	136.9	52.4	47.6	31.8	9.5	31.8	9.9	82.9	69.9	41.3	19.1	38.1	15.9	M8	SSUC206	SSFB206	1.09	
SSUCFB207	35	156.0	60.3	50.8	31.8	13.5	36.9	13.1	95.3	82.6	46.4	20.6	42.9	17.5	M10	SSUC207	SSFB207	1.64	
SSUCFB208	40	163.9	59.9	50.0	40.9	15.9	34.1	11.1	100.0	78.2	51.2	20.6	49.2	19.0	M10	SSUC208	SSFB208	2.29	
SSUCFB209	45	173.8	65.1	54.0	42.9	18.3	34.1	11.1	106.0	80.2	51.2	20.6	49.2	19.0	M10	SSUC209	SSFB209	2.59	
SSUCFB210	50	190.9	74.6	69.9	41.3	12.7	38.1	13.1	117.9	102.0	53.6	20.6	51.6	19.0	M10	SSUC210	SSFB210	3.14	



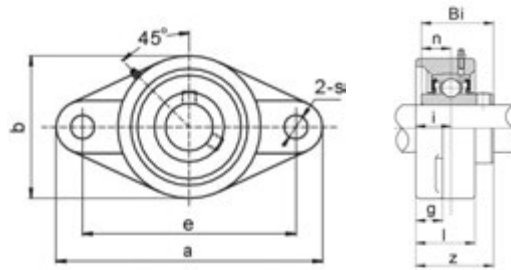

# STAINLESS STEEL TWO BOLT FLANGE

## Stainless Steel Insert

### SSUCFL 200 Series

- ✓ Solid Base
- ✓ Normal Duty
- ✓ Set Screw Locking

Unit No.	Shaft Dia. Inch	Inch Parts - Dimensions (inch)										Bolt Size	Bearing No.	Housing No.	Weight lbs
		a	e	b	g	l	s	z	i	Bi	n				
SSUCFL201-8	1/2												SSUC201-8	SSFL204	1.10
SSUCFL202-10	5/8	4-13/32	3-17/32	2-23/64	29/64	1	25/64	1-5/16	19/32	1.221	0.500	3/8	SSUC202-10		
SSUCFL204-12	3/4												SSUC204-12		
SSUCFL205-14	7/8												SSUC205-14	SSFL205	1.41
SSUCFL205-15	15/16	4-59/64	3-57/64	2-11/16	1/2	1-1/16	15/32	1-13/32	5/8	1.343	0.563	3/8	SSUC205-15		
SSUCFL205-16	1												SSUC205-16		
SSUCFL206-17	1-1/16												SSUC206-17	SSFL206	1.98
SSUCFL206-18	1-1/8	5-35/64	4-19/32	3-5/32	1/2	1-3/16	15/32	1-37/64	45/64	1.500	0.626	3/8	SSUC206-18		
SSUCFL206-19	1-3/16												SSUC206-19		
SSUCFL206-20	1-1/4S												SSUC206-20		
SSUCFL207-20	1-1/4												SSUC207-20	SSFL207	2.64
SSUCFL207-21	1-5/16	6-1/8	5-1/8	3-35/64	9/16	1-19/64	1/2	1-3/4	3/4	1.689	0.689	7/16	SSUC207-21		
SSUCFL207-22	1-3/8												SSUC207-22		
SSUCFL207-23	1-7/16												SSUC207-23		
SSUCFL208-24	1-1/2	6-3/4	5-21/32	3-15/16	9/16	1-27/64	1/2	2-1/64	13/16	1.937	0.748	7/16	SSUC208-24	SSFL208	3.59
SSUCFL209-26	1-5/8												SSUC209-26	SSFL209	4.05
SSUCFL209-27	1-11/16	7-3/64	5-27/32	4-1/4	9/16	1-1/2	19/32	2-3/64	55/64	1.937	0.748	5/8	SSUC209-27		
SSUCFL209-28	1-3/4												SSUC209-28		
SSUCFL210-30	1-7/8												SSUC210-30	SSFL210	4.75
SSUCFL210-31	1-15/16	7-7/16	6-3/16	4-17/32	19/32	1-17/32	19/32	2-9/64	55/64	2.032	0.748	5/8	SSUC210-31		
SSUCFL210-32	2S												SSUC210-32		
Unit No.	Shaft Dia. mm	Metric Parts - Dimensions (mm)										Bolt Size	Bearing No.	Housing No.	Weight kg
		a	e	b	g	l	s	z	i	Bi	n				
SSUCFL204	20	111.9	89.7	59.9	11.5	25.4	9.9	33.3	15.1	31.0	12.7	M8	SSUC204	SSFL204	0.50
SSUCFL205	25	125.0	98.8	68.3	12.7	27.0	11.9	35.7	15.9	34.1	14.3	M8	SSUC205	SSFL205	0.64
SSUCFL206	30	140.9	116.7	80.2	12.7	30.2	11.9	40.1	17.9	38.1	15.9	M8	SSUC206	SSFL206	0.90
SSUCFL207	35	155.6	130.2	90.1	14.3	32.9	12.7	44.5	19.1	42.9	17.5	M10	SSUC207	SSFL207	1.20
SSUCFL208	40	171.5	143.7	100.0	14.3	36.1	12.7	51.2	20.6	49.2	19.0	M10	SSUC208	SSFL208	1.63
SSUCFL209	45	179.0	148.4	108.0	14.3	38.1	15.1	52.0	21.8	49.2	19.0	M16	SSUC209	SSFL209	1.84
SSUCFL210	50	188.9	157.2	115.1	15.1	38.9	15.1	54.4	21.8	51.6	19.0	M16	SSUC210	SSFL210	2.16

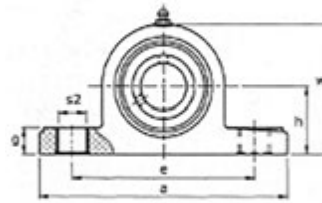
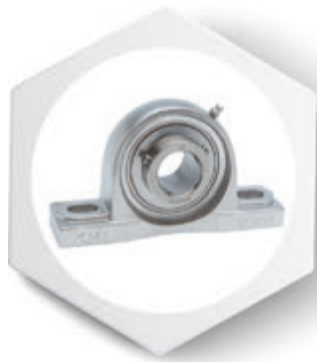

# STAINLESS STEEL PILLOW BLOCK

## Stainless Steel Insert

### SSUCP 200 Series

- ✓ Solid Base
- ✓ Normal Duty
- ✓ Set Screw Locking

Unit No.	Shaft Dia. Inch	Inch Parts - Dimensions (inch)										Bolt Size	Bearing No.	Housing No.	Weight lbs
		h	a	e	b	S1	S2	g	w	Bi	n				
SSUCP201-8	1/2	1-5/16	5	3-3/4	1-1/2	1/2	11/16	19/32	2-9/16	1.221	0.500	3/8	SSUC201-8	SSP204	1.91
SSUCP202-10	5/8												SSUC202-10		
SSUCP204-12	3/4												SSUC204-12		
SSUCP205-14	7/8	1-7/16	5-33/64	4-1/8	1-1/2	1/2	11/16	5/8	2-3/4	1.343	0.563	3/8	SSUC205-14	SSP205	2.07
SSUCP205-15	15/16												SSUC205-15		
SSUCP205-16	1												SSUC205-16		
SSUCP206-17	1-1/16	1-11/16	6-1/2	4-49/64	1-7/8	5/8	13/16	23/32	3-9/32	1.500	0.626	1/2	SSUC206-17	SSP206	3.54
SSUCP206-18	1-1/8												SSUC206-18		
SSUCP206-19	1-3/16												SSUC206-19		
SSUCP206-20	1-1/4S												SSUC206-20		
SSUCP207-20	1-1/4	1-7/8	6-9/16	5	1-7/8	5/8	7/8	3/4	3-11/16	1.689	0.689	1/2	SSUC207-20	SSP207	4.18
SSUCP207-21	1-5/16												SSUC207-21		
SSUCP207-22	1-3/8												SSUC207-22		
SSUCP207-23	1-7/16												SSUC207-23		
SSUCP208-24	1-1/2	1-15/16	7-1/4	5-25/64	2-1/8	9/16	7/8	3/4	3-15/16	1.937	0.748	1/2	SSUC208-24	SSP208	5.41
SSUCP209-26	1-5/8	2-1/8	7-15/32	5-3/4	2-1/8	9/16	13/16	25/32	4-19/64	1.937	0.748	1/2	SSUC209-26	SSP209	6.10
SSUCP209-27	1-11/16												SSUC209-27		
SSUCP209-28	1-3/4												SSUC209-28		
SSUCP210-30	1-7/8	2-1/4	8-1/8	6-1/4	2-23/64	11/16	15/16	7/8	4-1/2	2.032	0.748	5/8	SSUC210-30	SSP210	6.99
SSUCP210-31	1-15/16												SSUC210-31		
SSUCP210-32	2S												SSUC210-32		
SSUCP211-32	2	2-1/2	8-17/32	6-7/8	2-3/8	3/4	15/16	7/8	4-15/16	2.189	0.875	5/8	SSUC211-32	SSP211	7.40
Unit No.	Shaft Dia. mm	Metric Parts - Dimensions (mm)										Bolt Size	Bearing No.	Housing No.	Weight kg
		h	a	e	b	S1	S2	g	w	Bi	n				
SSUCP204	20	33.3	127.0	95.3	38.1	13.0	17.5	15.1	65.1	31.0	12.7	M10	SSUC204	SSP204	0.87
SSUCP205	25	36.5	140.1	104.8	38.1	13.0	17.5	15.9	69.9	34.1	14.3	M10	SSUC205	SSP205	0.94
SSUCP206	30	42.9	165.1	121.0	47.6	17.0	20.6	18.3	83.3	38.1	15.9	M12	SSUC206	SSP206	1.61
SSUCP207	35	47.6	166.7	127.0	47.6	17.0	22.2	19.1	93.7	42.9	17.5	M12	SSUC207	SSP207	1.90
SSUCP208	40	49.2	184.2	136.9	54.0	15.0	22.2	19.1	100.0	49.2	19.0	M12	SSUC208	SSP208	2.46
SSUCP209	45	54.0	189.7	146.1	54.0	15.0	20.6	19.8	109.1	49.2	19.0	M14	SSUC209	SSP209	2.77
SSUCP210	50	57.2	206.4	158.8	59.9	18.0	23.8	22.2	114.3	51.6	19.0	M16	SSUC210	SSP210	3.18
SSUCP211	55	63.5	216.7	174.6	60.3	20.0	23.8	22.2	125.4	55.6	22.2	M18	SSUC211	SSP211	3.36

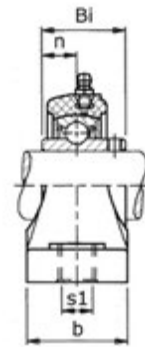
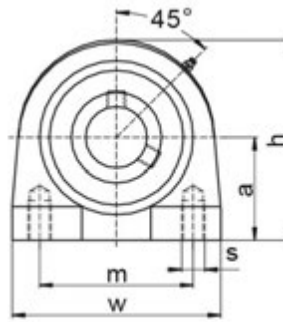
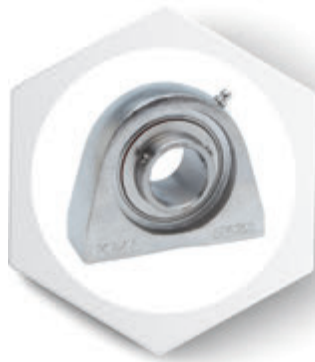

# STAINLESS STEEL TAP BASE PILLOW BLOCK

## Stainless Steel Insert

### SSUCA 200 Series

- ✓ Normal Duty
- ✓ Set Screw Locking
- ✓ Inch Bolt Holes

Unit No.	Shaft Dia. Inch	Inch Parts - Dimensions (inch)								Bearing No.	Housing No.	Weight lbs
		h	a	m	b	s	w	Bi	n			
SSUCA201-8	1/2									SSUC201-8		
SSUCA202-10	5/8	2-9/16	1-5/16	2	1-1/2	3/8 - 16	2-7/8	1.221	0.500	SSUC202-10	SSPA204	1.54
SSUCA204-12	3/4									SSUC204-12		
SSUCA205-14	7/8									SSUC205-14	SSPA205	1.87
SSUCA205-15	15/16	2-51/64	1-7/16	2	1-1/2	3/8 - 16	3	1.343	0.563	SSUC205-15		
SSUCA205-16	1									SSUC205-16		
SSUCA206-17	1-1/16									SSUC206-17	SSPA206	2.42
SSUCA206-18	1-1/8	3-5/16	1-11/16	3	1-1/2	7/16 - 14	4	1.500	0.626	SSUC206-18		
SSUCA206-19	1-3/16									SSUC206-19		
SSUCA206-20	1-1/4S									SSUC206-20		
SSUCA207-20	1-1/4											
SSUCA207-21	1-5/16	3-3/4	1-7/8	3-1/4	1-57/64	1/2 - 13	4-1/4	1.689	0.689	SSUC207-21	SSPA207	3.15
SSUCA207-22	1-3/8									SSUC207-22		
SSUCA207-23	1-7/16									SSUC207-23		
SSUCA208-24	1-1/2									3-15/16		
SSUCA209-26	1-5/8									SSUC209-26	SSPA209	5.50
SSUCA209-27	1-11/16	4-1/4	2-1/8	3-3/4	2-1/64	1/2 - 13	5	1.937	0.748	SSUC209-27		
SSUCA209-28	1-3/4									SSUC209-28		
SSUCA210-30	1-7/8									SSUC210-30	SSPA210	6.82
SSUCA210-31	1-15/16	4-39/64	2-1/4	4	2-1/64	5/8 - 11	5-33/64	2.032	0.748	SSUC210-31		
SSUCA210-32	2S									SSUC210-32		
Unit No.	Shaft Dia. mm	Metric Parts - Dimensions (mm)								Bearing No.	Housing No.	Weight kg
		h	a	m	b	s	w	Bi	n			
SSUCA204	20	65.1	33.3	50.8	38.1	3/8 - 16	73.0	31.0	12.7	SSUC204	SSPA204	0.70
SSUCA205	25	71.0	36.5	50.8	38.1	3/8 - 16	76.2	34.1	14.3	SSUC205	SSPA205	0.85
SSUCA206	30	84.1	42.9	76.2	38.1	7/16 - 14	101.6	38.1	15.9	SSUC206	SSPA206	1.10
SSUCA207	35	95.3	47.6	82.6	48.0	1/2 - 13	108.0	42.9	17.5	SSUC207	SSPA207	1.43
SSUCA208	40	100.0	49.2	88.9	48.0	1/2 - 13	115.9	49.2	19.0	SSUC208	SSPA208	1.80
SSUCA209	45	108.0	54.0	95.3	51.2	1/2 - 13	127.0	49.2	19.0	SSUC209	SSPA209	2.50
SSUCA210	50	117.1	57.2	101.6	51.2	5/8 - 11	140.1	51.6	19.0	SSUC210	SSPA210	3.10

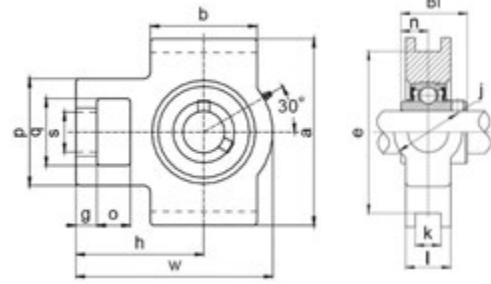

# STAINLESS STEEL TAKE-UP UNIT

## Stainless Steel Insert

### SSUCT 200 Series

- ✓ Normal Duty
- ✓ Set Screw Locking
- ✓ Metric Slot Width

Unit No.	Shaft Dia. Inch	Inch Parts - Dimensions (inch)															Bearing No.	Housing No.	Weight lbs
		o	g	p	q	s	h	a	b	k	e	w	l	j	Bi	n			
SSUCT201-8	1/2																SSUC201-8	SST204	2.00
SSUCT202-10	5/8	5/8	13/32	2	1-1/4	3/4	2-13/32	3-1/2	2	12	3	3-11/16	13/16	1-1/4	1.220	0.500	SSUC202-10		
SSUCT204-12	3/4																SSUC204-12		
SSUCT205-14	7/8																SSUC205-14	SST205	2.18
SSUCT205-15	15/16	5/8	13/32	2	1-1/4	3/4	2-7/16	3-1/2	2	12	3	3-13/16	15/16	1-1/4	1.343	0.563	SSUC205-15		
SSUCT205-16	1																SSUC205-16		
SSUCT206-17	1-1/16																SSUC206-17	SST206	3.21
SSUCT206-18	1-1/8	5/8	13/32	2-7/32	1-29/64	7/8	2-3/4	4-1/64	2-1/4	12	3-1/2	4-7/16	1-3/32	1-29/64	1.500	0.626	SSUC206-18		
SSUCT206-19	1-3/16																SSUC206-19		
SSUCT206-20	1-1/4S																SSUC206-20		
SSUCT207-20	1-1/4																SSUC207-20	SST207	3.98
SSUCT207-21	1-5/16	5/8	1/2	2-33/64	1-29/64	7/8	3-5/64	4-1/64	2-33/64	12	3-1/2	5-5/64	1-3/16	1-29/64	1.689	0.689	SSUC207-21		
SSUCT207-22	1-3/8																SSUC207-22		
SSUCT207-23	1-7/16																SSUC207-23		
SSUCT208-24	1-1/2	3/4	5/8	3-9/32	1-59/64	1-9/64	3-15/32	4-1/2	3-9/32	16	4-1/64	5-19/32	1-19/64	1-59/64	1.937	0.748	SSUC208-24	SST208	5.90
SSUCT209-26	1-5/8																SSUC209-26	SST209	6.58
SSUCT209-27	1-11/16	3/4	5/8	3-9/32	1-59/64	1-9/64	3-27/64	4-19/32	3-9/32	16	4-1/64	5-11/16	1-3/8	1-59/64	1.937	0.748	SSUC209-27		
SSUCT209-28	1-3/4																SSUC209-28		
SSUCT210-30	1-7/8																SSUC210-30	SST210	6.62
SSUCT210-31	1-15/16	3/4	5/8	3-9/32	1-59/64	1-9/64	3-35/64	4-19/32	3-25/64	16	4-1/64	5-55/64	1-29/64	1-59/64	2.031	0.748	SSUC210-31		
SSUCT210-32	2S																SSUC210-32		
Unit No.	Shaft Dia. mm	Metric Parts - Dimensions (mm)															Bearing No.	Housing No.	Weight kg
		o	g	p	q	s	h	a	b	k	e	w	l	j	Bi	n			
SSUCT204	20	15.9	10.3	50.8	31.8	19.1	61.1	88.9	50.8	12	76.2	93.7	20.6	31.8	31.0	12.7	SSUC204	SST204	0.91
SSUCT205	25	15.9	10.3	50.8	31.8	19.1	61.9	88.9	50.8	12	76.2	96.8	23.8	31.8	34.1	14.3	SSUC205	SST205	0.99
SSUCT206	30	15.9	10.3	56.4	36.9	22.2	69.9	102.0	57.2	12	88.9	112.7	27.8	36.9	38.1	15.9	SSUC206	SST206	1.46
SSUCT207	35	15.9	12.7	63.9	36.9	22.2	78.2	102.0	63.9	12	88.9	129.0	30.2	36.9	42.9	17.5	SSUC207	SST207	1.81
SSUCT208	40	19.1	15.9	83.3	48.8	29.0	88.1	114.3	83.3	16	102.0	142.1	32.9	48.8	49.2	19.0	SSUC208	SST208	2.68
SSUCT209	45	19.1	15.9	83.3	48.8	29.0	86.9	116.7	83.3	16	102.0	144.5	34.9	48.8	49.2	19.0	SSUC209	SST209	2.99
SSUCT210	50	19.1	15.9	83.3	48.8	29.0	90.1	116.7	86.1	16	102.0	148.8	36.9	48.8	51.6	19.0	SSUC210	SST210	3.01



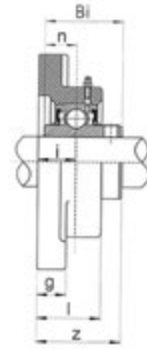
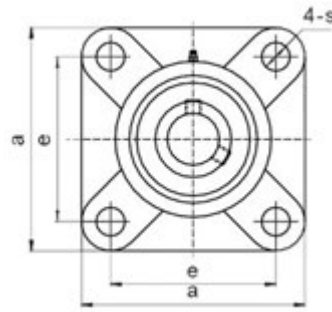

# THERMOPLASTIC FOUR BOLT FLANGE

## Stainless Steel Insert

### SSUCTPF 200 Series

- ✓ Solid Base
- ✓ Normal Duty
- ✓ Set Screw Locking

Unit No.	Shaft Dia. Inch	Inch Parts - Dimensions (inch)									Bolt Size	Bearing No.	Housing No.	Weight lbs
		a	e	g	l	s	z	i	Bi	n				
SSUCTPF201-8	1/2											SSUC201-8	TPF204	0.66
SSUCTPF202-10	5/8	3-3/8	2-1/2	17/32	1-3/32	7/16	1-23/64	41/64	1.221	0.500	3/8	SSUC202-10		
SSUCTPF204-12	3/4											SSUC204-12		
SSUCTPF205-14	7/8											SSUC205-14	TPF205	0.77
SSUCTPF205-15	15/16	3-3/4	2-3/4	9/16	1-1/8	7/16	1-7/16	21/32	1.339	0.563	3/8	SSUC205-15		
SSUCTPF205-16	1											SSUC205-16		
SSUCTPF206-17	1-1/16											SSUC206-17	TPF206	1.12
SSUCTPF206-18	1-1/8	4-7/32	3-9/32	9/16	1-1/4	7/16	1-5/8	3/4	1.500	0.626	3/8	SSUC206-18		
SSUCTPF206-19	1-3/16											SSUC206-19		
SSUCTPF206-20	1-1/4S											SSUC206-20		
SSUCTPF207-20	1-1/4													
SSUCTPF207-21	1-5/16	4-5/8	3-5/8	39/64	1-23/64	1/2	1-3/4	3/4	1.689	0.689	7/16	SSUC207-21	TPF207	1.61
SSUCTPF207-22	1-3/8											SSUC207-22		
SSUCTPF207-23	1-7/16											SSUC207-23		
SSUCTPF208-24	1-1/2											5-1/8		
SSUCTPF209-26	1-5/8	5-3/8	4-1/8	3/4	1-5/8	21/32	2-1/8	15/16	1.937	0.748	1/2	SSUC209-26	TPF209	2.60
SSUCTPF209-27	1-11/16											SSUC209-27		
SSUCTPF209-28	1-3/4											SSUC209-28		
SSUCTPF210-30	1-7/8	5-5/8	4-3/8	13/16	1-11/16	21/32	2-17/64	31/32	2.032	0.748	1/2	SSUC210-30	TPF210	2.86
SSUCTPF210-31	1-15/16											SSUC210-31		
SSUCTPF210-32	2S											SSUC210-32		
Unit No.	Shaft Dia. mm	Metric Parts - Dimensions (mm)									Bolt Size	Bearing No.	Housing No.	Weight kg
		a	e	g	l	s	z	i	Bi	n				
SSUCTPF204	20	85.7	63.5	13.5	27.8	11.1	34.5	16.3	31.0	12.7	M8	SSUC204	TPF204	0.30
SSUCTPF205	25	95.3	69.9	14.3	28.6	11.1	36.5	16.7	34.0	14.3	M8	SSUC205	TPF205	0.35
SSUCTPF206	30	107.2	83.3	14.3	31.8	11.1	41.3	19.1	38.1	15.9	M8	SSUC206	TPF206	0.51
SSUCTPF207	35	117.5	92.1	15.5	34.5	12.7	44.5	19.1	42.9	17.5	M10	SSUC207	TPF207	0.73
SSUCTPF208	40	130.2	102.0	16.7	36.5	14.3	53.2	23.0	49.2	19.0	M10	SSUC208	TPF208	1.01
SSUCTPF209	45	136.5	104.8	19.1	41.3	16.7	54.0	23.8	49.2	19.0	M16	SSUC209	TPF209	1.18
SSUCTPF210	50	142.9	111.1	20.6	42.9	16.7	57.5	24.6	51.6	19.0	M16	SSUC210	TPF210	1.30

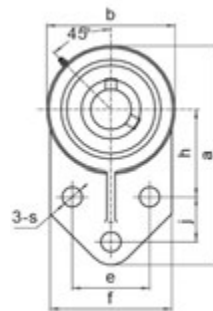

# THERMOPLASTIC FLANGE BRACKET

## Stainless Steel Insert

### SSUCTPFB 200 Series

- ✓ Normal Duty
- ✓ Set Screw Locking
- ✓ Inch Dimension

Unit No.	Shaft Dia. Inch	Inch Parts - Dimensions (inch)														Bolt Size	Bearing No.	Housing No.	Weight lbs
		a	h	e	j	g	l	s	b	f	z	i	Bi	n					
SSUCTPFB201-8	1/2	4-1/4	1-11/16	1-1/2	7/8	29/64	1-3/64	27/64	2-1/2	2-7/16	1-11/32	5/8	1.219	0.500	5/16	SSUC201-8	TPFB204	0.57	
SSUCTPFB202-10	5/8															SSUC202-10			
SSUCTPFB204-12	3/4															SSUC204-12			
SSUCTPFB205-14	7/8	4-3/4	1-13/16	1-5/8	1-1/8	29/64	1-7/64	27/64	2-3/4	2-1/2	1-7/16	21/32	1.343	5/16	SSUC205-14	TPFB205	0.68		
SSUCTPFB205-15	15/16														SSUC205-15				
SSUCTPFB205-16	1														SSUC205-16				
SSUCTPFB206-17	1-1/16	5-29/64	2-1/16	1-7/8	1-1/4	17/32	1-1/4	27/64	3-9/32	3	1-39/64	47/64	1.500	0.626	5/16	SSUC206-17	TPFB206	1.08	
SSUCTPFB206-18	1-1/8															SSUC206-18			
SSUCTPFB206-19	1-3/16															SSUC206-19			
SSUCTPFB206-20	1-1/4S															SSUC206-20			
SSUCTPFB207-20	1-1/4	6-3/16	2-3/8	2	1-1/4	41/64	1-1/4	33/64	3-3/4	3-1/2	1-53/64	13/16	1.689	3/8	SSUC207-20	TPFB207	1.56		
SSUCTPFB207-21	1-5/16														SSUC207-21				
SSUCTPFB207-22	1-3/8														SSUC207-22				
SSUCTPFB207-23	1-7/16														SSUC207-23				
Unit No.	Shaft Dia. mm	Metric Parts - Dimensions (mm)														Bolt Size	Bearing No.	Housing No.	Weight kg
		a	h	e	j	g	l	s	b	f	z	i	Bi	n					
SSUCTPFB204	20	108.0	42.9	38.1	22.2	11.5	26.6	10.7	63.5	61.9	34.1	15.9	31.0	12.7	M8	SSUC204	TPFB204	0.26	
SSUCTPFB205	25	120.7	46.0	41.3	28.6	11.5	28.2	10.7	69.9	63.5	36.5	16.7	34.1	14.3	M8	SSUC205	TPFB205	0.31	
SSUCTPFB206	30	138.5	52.4	47.6	31.8	13.5	31.8	10.7	83.3	76.2	40.9	18.7	38.1	15.9	M8	SSUC206	TPFB206	0.49	
SSUCTPFB207	35	157.2	60.3	50.8	31.8	16.3	31.8	13.1	95.3	88.9	46.4	20.6	42.9	17.5	M10	SSUC207	TPFB207	0.71	

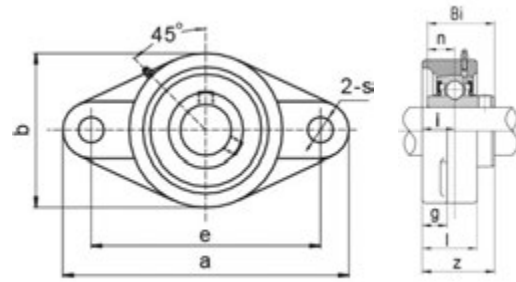

# THERMOPLASTIC TWO BOLT FLANGE

## Stainless Steel Insert

### SSUCTPFL 200 Series

- ✓ Solid Base
- ✓ Normal Duty
- ✓ Set Screw Locking

Unit No.	Shaft Dia. Inch	Inch Parts - Dimensions (inch)										Bolt Size	Bearing No.	Housing No.	Weight lbs	
		a	e	b	g	l	s	z	i	Bi	n					
SSUCTPFL201-8	1/2													SSUC201-8		
SSUCTPFL202-10	5/8	4-7/16	3-35/64	2-9/16	17/32	1-3/64	7/16	1-5/16	19/32	1.221	0.500	3/8	SSUC202-10	TPFL204	0.57	
SSUCTPFL204-12	3/4												SSUC204-12			
SSUCTPFL205-14	7/8												SSUC205-14			
SSUCTPFL205-15	15/16	5-5/32	3-57/64	2-3/4	9/16	1-7/64	7/16	1-27/64	21/32	1.343	0.563	3/8	SSUC205-15	TPFL205	0.68	
SSUCTPFL205-16	1												SSUC205-16			
SSUCTPFL206-17	1-1/16	5-13/16	4-19/32	3-5/32	9/16	1-13/64	7/16	1-37/64	23/32	1.500	0.626	3/8	SSUC206-17	TPFL206	1.01	
SSUCTPFL206-18	1-1/8												SSUC206-18			
SSUCTPFL206-19	1-3/16												SSUC206-19			
SSUCTPFL206-20	1-1/4S												SSUC206-20			
SSUCTPFL207-20	1-1/4	6-7/16	5-1/8	3-35/64	39/64	1-17/64	1/2	1-3/4	3/4	1.689	0.689	1/2	SSUC207-20	TPFL207	1.41	
SSUCTPFL207-21	1-5/16												SSUC207-21			
SSUCTPFL207-22	1-3/8												SSUC207-22			
SSUCTPFL207-23	1-7/16												SSUC207-23			
SSUCTPFL208-24	1-1/2	6-15/16	5-11/16	3-15/16	21/32	1-3/8	9/16	2-1/32	27/32	1.937	0.748	1/2	SSUC208-24	TPFL208	1.91	
SSUCTPFL209-26	1-5/8	7-7/16	5-7/8	4-1/4	13/16	1-5/8	21/32	2-1/8	15/16	1.937	0.748	1/2	SSUC209-26	TPFL209	2.24	
SSUCTPFL209-27	1-11/16												SSUC209-27			
SSUCTPFL209-28	1-3/4												SSUC209-28			
SSUCTPFL210-30	1-7/8	7-3/4	6-3/16	4-17/32	13/16	1-11/16	21/32	2-17/64	31/32	2.032	0.748	5/8	SSUC210-30	TPFL210	2.50	
SSUCTPFL210-31	1-15/16												SSUC210-31			
SSUCTPFL210-32	2S												SSUC210-32			
Unit No.	Shaft Dia. mm	Metric Parts - Dimensions (mm)										Bolt Size	Bearing No.	Housing No.	Weight kg	
		a	e	b	g	l	s	z	i	Bi	n					
SSUCTPFL204	20	112.7	90.1	65.1	13.5	26.6	11.1	33.3	15.1	31.0	12.7	M8	SSUC204	TPFL204	0.26	
SSUCTPFL205	25	131.0	98.8	69.9	14.3	28.2	11.1	36.1	16.7	34.1	14.3	M8	SSUC205	TPFL205	0.31	
SSUCTPFL206	30	147.6	116.7	80.2	14.3	30.6	11.1	40.1	18.3	38.1	15.9	M8	SSUC206	TPFL206	0.46	
SSUCTPFL207	35	163.5	130.2	90.1	15.5	32.1	12.7	44.5	19.1	42.9	17.5	M10	SSUC207	TPFL207	0.64	
SSUCTPFL208	40	176.2	144.5	100.0	16.7	34.9	14.3	51.6	21.4	49.2	19.0	M10	SSUC208	TPFL208	0.87	
SSUCTPFL209	45	188.9	149.2	108.0	20.6	41.3	16.7	54.0	23.8	49.2	19.0	M16	SSUC209	TPFL209	1.02	
SSUCTPFL210	50	196.9	157.2	115.1	20.6	42.9	16.7	57.5	24.6	51.6	19.0	M16	SSUC210	TPFL210	1.14	

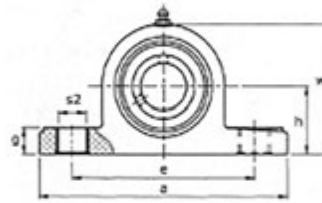

# THERMOPLASTIC PILLOW BLOCK

## Stainless Steel Insert

### SSUCTPP 200 Series

- ✓ Solid Base
- ✓ Normal Duty
- ✓ Set Screw Locking

Unit No.	Shaft Dia. Inch	Inch Parts - Dimensions (inch)										Bolt Size	Bearing No.	Housing No.	Weight lbs
		h	a	e	b	S1	S2	g	w	Bi	n				
SSUCTPP201-8	1/2	1-5/16	5	3-3/4	1-1/2	7/16	9/16	9/16	2-37/64	1.221	0.500	3/8	SSUC201-8	TPP204	0.68
SSUCTPP202-10	5/8												SSUC202-10		
SSUCTPP204-12	3/4												SSUC204-12		
SSUCTPP205-14	7/8	1-7/16	5-9/16	4-1/8	1-1/2	7/16	9/16	37/64	2-51/54	1.343	0.563	3/8	SSUC205-14	TPP205	0.75
SSUCTPP205-15	15/16												SSUC205-15		
SSUCTPP205-16	1												SSUC205-16		
SSUCTPP206-17	1-1/16	1-11/16	6-13/32	4-11/16	1-13/16	9/16	23/32	45/64	3-5/16	1.500	0.626	1/2	SSUC206-17	TPP206	1.25
SSUCTPP206-18	1-1/8												SSUC206-18		
SSUCTPP206-19	1-3/16												SSUC206-19		
SSUCTPP206-20	1-1/4S												SSUC206-20		
SSUCTPP207-20	1-1/4	1-7/8	6-5/8	5	1-7/8	9/16	23/32	23/32	3-23/32	1.689	0.689	1/2	SSUC207-20	TPP207	1.65
SSUCTPP207-21	1-5/16												SSUC207-21		
SSUCTPP207-22	1-3/8												SSUC207-22		
SSUCTPP207-23	1-7/16												SSUC207-23		
SSUCTPP208-24	1-1/2	1-15/16	7-1/4	5-25/64	2-1/8	9/16	23/32	49/64	3-31/32	1.937	0.748	1/2	SSUC208-24	TPP208	2.20
SSUCTPP209-26	1-5/8	2-1/8	7-9/16	5-3/4	2-1/8	21/32	25/32	29/32	4-11/64	1.937	0.748	1/2	SSUC209-26	TPP209	2.58
SSUCTPP209-27	1-11/16												SSUC209-27		
SSUCTPP209-28	1-3/4												SSUC209-28		
SSUCTPP210-30	1-7/8	2-1/4	8-1/8	6-1/4	2-3/8	21/32	25/32	29/32	4-1/2	2.032	0.748	5/8	SSUC210-30	TPP210	2.80
SSUCTPP210-31	1-15/16												SSUC210-31		
SSUCTPP210-32	2S												SSUC210-32		
Unit No.	Shaft Dia. mm	Metric Parts - Dimensions (mm)										Bolt Size	Bearing No.	Housing No.	Weight kg
		h	a	e	b	S1	S2	g	w	Bi	n				
SSUCTPP204	20	33.3	127.0	95.3	38.1	11.1	14.3	14.3	65.5	31.0	12.7	M8	SSUC204	TPP204	0.31
SSUCTPP205	25	36.5	141.3	104.8	38.1	11.1	14.3	14.7	71.0	34.1	14.3	M8	SSUC205	TPP205	0.34
SSUCTPP206	30	42.9	162.7	119.1	46.0	14.3	18.3	17.9	84.1	38.1	15.9	M10	SSUC206	TPP206	0.57
SSUCTPP207	35	47.6	168.3	127.0	47.6	14.3	18.3	18.3	94.5	42.9	17.5	M10	SSUC207	TPP207	0.75
SSUCTPP208	40	49.2	184.2	136.9	54.0	14.3	18.3	19.4	100.8	49.2	19.0	M10	SSUC208	TPP208	1.00
SSUCTPP209	45	54.0	192.1	146.1	54.0	16.7	19.8	23.0	106.0	49.2	19.0	M16	SSUC209	TPP209	1.17
SSUCTPP210	50	57.2	206.4	158.8	60.3	16.7	19.8	23.0	114.3	51.6	19.0	M16	SSUC210	TPP210	1.27



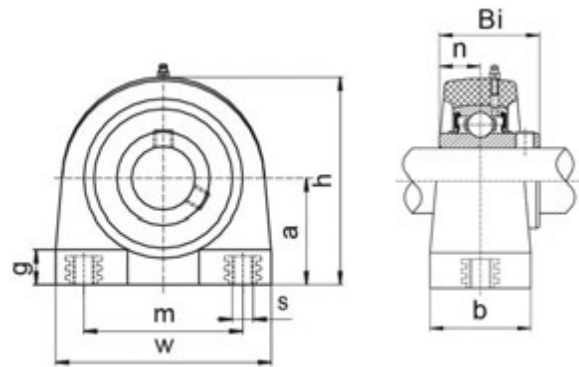

# THERMOPLASTIC TAP BASE PILLOW BLOCK

## Stainless Steel Insert

### SSUCTPTB 200 Series

- ✓ Normal Duty
- ✓ Set Screw Locking
- ✓ Inch Bolt Holes

Unit No.	Shaft Dia. Inch	Inch Parts - Dimensions (inch)										Bearing No.	Housing No.	Weight lbs
		h	a	m	b	S	g	w	Bi	n				
SSUCTPTB201-8	1/2											SSUC201-8		
SSUCTPTB202-10	5/8	2-19/32	1-5/16	2	1-23/64	3/8 - 16	1/2	2-7/8	1.221	0.500		SSUC202-10	TPTB204	0.59
SSUCTPTB204-12	3/4											SSUC204-12		
SSUCTPTB205-14	7/8											SSUC205-14		
SSUCTPTB205-15	15/16	2-57/64	1-7/16	2	1-9/16	3/8 - 16	1/2	3	1.343	0.563		SSUC205-15	TPTB205	0.69
SSUCTPTB205-16	1											SSUC205-16		
SSUCTPTB206-17	1-1/16											SSUC206-17		
SSUCTPTB206-18	1-1/8	3-5/16	1-11/16	3	1-43/64	7/16 - 14	5/8	3-31/32	1.500	0.626		SSUC206-18	TPTB206	1.10
SSUCTPTB206-19	1-3/16											SSUC206-19		
SSUCTPTB206-20	1-1/4S											SSUC206-20		
SSUCTPTB207-20	1-1/4											SSUC207-20		
SSUCTPTB207-21	1-5/16	3-3/4	1-7/8	3-1/4	1-7/8	1/2 - 13	23/32	4-11/32	1.689	0.689		SSUC207-21	TPTB207	1.61
SSUCTPTB207-22	1-3/8											SSUC207-22		
SSUCTPTB207-23	1-7/16											SSUC207-23		
SSUCTPTB208-24	1-1/2	3-61/64	1-15/16	3-1/2	1-57/64	1/2 - 13	25/32	4-23/32	1.689	0.748		SSUC208-24	TPTB208	2.07
SSUCTPTB209-26	1-5/8											SSUC209-26		
SSUCTPTB209-27	1-11/16	4-17/64	2-1/8	3-3/4	1-31/32	1/2 - 13	25/32	4-7/8	1.937	0.748		SSUC209-27	TPTB209	2.42
SSUCTPTB209-28	1-3/4											SSUC209-28		
SSUCTPTB210-30	1-7/8											SSUC210-30		
SSUCTPTB210-31	1-15/16	4-17/32	2-1/4	4	2-1/8	5/8 - 11	7/8	5-5/16	2.032	0.748		SSUC210-31	TPTB210	2.73
SSUCTPTB210-32	2S											SSUC210-32		
Unit No.	Shaft Dia. mm	Metric Parts - Dimensions (mm)										Bearing No.	Housing No.	Weight kg
		h	a	m	b	S	g	w	Bi	n				
SSUCTPTB204	20	65.9	33.3	50.8	34.5	3/8 - 16	12.7	73.0	31.0	12.7		SSUC204	TPTB204	0.27
SSUCTPTB205	25	73.4	36.5	50.8	39.7	3/8 - 16	12.7	76.2	34.1	14.3		SSUC205	TPTB205	0.31
SSUCTPTB206	30	84.1	42.9	76.2	42.5	7/16 - 14	15.9	100.8	38.1	15.9		SSUC206	TPTB206	0.50
SSUCTPTB207	35	95.3	47.6	82.6	47.6	1/2 - 13	18.3	110.3	42.9	17.5		SSUC207	TPTB207	0.73
SSUCTPTB208	40	100.4	49.2	88.9	48.0	1/2 - 13	19.8	119.9	42.9	19.0		SSUC208	TPTB208	0.94
SSUCTPTB209	45	108.3	54.0	95.3	50.0	1/2 - 13	19.8	123.8	49.2	19.0		SSUC209	TPTB209	1.10
SSUCTPTB210	50	115.1	57.2	101.6	54.0	5/8 - 11	22.2	134.9	51.6	19.0		SSUC210	TPTB210	1.24



## THERMOPLASTIC CLOSED CAPS

### Closed Covers for TPF, TPFB, TPFL, TPP, TPTB Housing

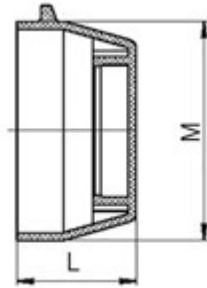

Part Number	Inch Parts - Dimensions (inch)	
	L	M
CC204	0.906	1.969
CC205	0.984	2.165
CC206	1.181	2.520
CC207	1.260	2.933
CC208	1.457	3.307

## THERMOPLASTIC OPEN CAPS

### Open Covers for TPF, TPFB, TPFL, TPP, TPTB Housing

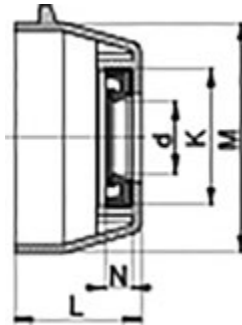

Part Number	Inch Parts - Dimensions (inch)				
	K	N	L	M	d
OC204-8					1/2
OC204-10	1.260	0.276	0.906	1.969	5/8
OC204-12					3/4
OC205-14					7/8
OC205-15	1.457	0.276	0.984	2.165	15/16
OC205-16					1
OC206-17	1.654	0.276	1.181	2.520	1-1/16
OC206-18					1-1/8
OC206-19					1-3/16
OC206-20					1-1/4S
OC207-20					1-1/4
OC207-21	1.850	0.276	1.260	2.933	1-5/16
OC207-22					1-3/8
OC207-23					1-7/16
OC208-24	2.047	0.276	1.457	3.307	1-1/2
OC208-25					1-9/16
Part Number	Metric Parts - Dimensions (mm)				
	K	N	L	M	d
OC204	32.0	7.0	23.0	50.0	20.0
OC205	37.0	7.0	25.0	55.0	25.0
OC206	42.0	7.0	30.0	64.0	30.0
OC207	47.0	7.0	32.0	74.5	35.0
OC208	52.0	7.0	37.0	84.0	40.0

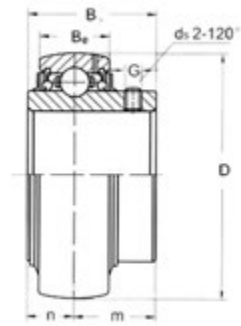

# ALL STAINLESS STEEL INSERT BEARINGS

## Wide Inner Ring Bearing

### SSUC 200 Series

- ✓ Normal Duty
- ✓ Set Screw Locking

Unit No.	Shaft Dia. Inch	Inch Parts - Dimensions (inch)							Basic Load Ratings lbf / N		Weight lbs
		D	Bi	Be	n	m	G	ds	Dynamic C	Static Co	
SSUC201-8	1/2	1.850	1.250	5/8	0.500	23/32	0.197	1/4 - 28UNF	2465	1241	0.46
SSUC202-10	5/8										0.42
SSUC204-12	3/4										0.40
SSUC205-14	7/8	2.047	1.344	21/32	0.563	25/32	0.216	1/4 - 28UNF	2678	1445	0.51
SSUC205-15	15/16										0.46
SSUC205-16	1										0.44
SSUC206-17	1-1/16	2.441	1.500	3/4	0.625	7/8	0.234	1/4 - 28UNF	3732	2134	0.81
SSUC206-18	1-1/8										0.77
SSUC206-19	1-3/16										0.73
SSUC206-20	1-1/4S										0.66
SSUC207-20	1-1/4	2.835	1.688	25/32	0.688	1	0.256	5/16 - 24UNF	4905	2933	1.21
SSUC207-21	1-5/16										1.14
SSUC207-22	1-3/8										1.08
SSUC207-23	1-7/16										1.01
SSUC208-24	1-1/2										3.150
SSUC208-25	1-9/16	1.47									
SSUC209-26	1-5/8	3.346	1.938	7/8	0.750	1-3/16	0.313	5/16 - 24UNF	6248	3485	1.76
SSUC209-27	1-11/16										1.67
SSUC209-28	1-3/4										1.56
SSUC210-30	1-7/8	3.543	2.031	15/16	0.750	1-9/32	0.344	3/8 - 24UNF	6715	3987	1.91
SSUC210-31	1-15/16										1.80
SSUC210-32	2S										1.69
SSUC211-32	2	3.937	2.188	31/32	0.875	1-5/16	0.344	3/8 - 24UNF	8288	4973	2.71
Unit No.	Shaft Dia. mm	Metric Parts - Dimensions (mm)							Basic Load Ratings lbf / N		Weight kg
		D	Bi	Be	n	m	G	ds	Dynamic C	Static Co	
SSUC204	20	47.0	31.8	15.9	12.7	18.3	5.0	M6x1.0	10957	5517	0.17
SSUC205	25	52.0	34.1	16.7	14.3	19.8	5.5	M6x1.0	11900	6426	0.20
SSUC206	30	62.0	38.1	19.1	15.9	22.2	6.0	M6x1.0	16584	9486	0.33
SSUC207	35	72.0	42.9	19.8	17.5	25.4	6.5	M8x1.0	21794	13031	0.40
SSUC208	40	80.0	49.2	20.6	19.1	30.2	7.9	M8x1.0	24557	14544	0.65
SSUC209	45	85.0	49.2	22.2	19.1	30.2	7.9	M8x1.0	27770	15487	0.70
SSUC210	50	90.0	51.6	23.8	19.1	32.5	8.7	M10x1.25	29844	17714	0.80
SSUC211	55	100.0	55.6	24.6	22.2	33.3	8.7	M10x1.25	36831	22100	1.08

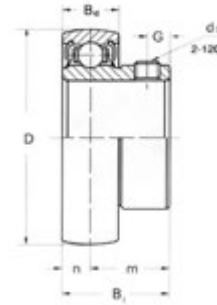

# ALL STAINLESS STEEL INSERT BEARINGS

## Narrow Inner Ring Bearing

### SSSB 200 Series

- ✓ Light Duty
- ✓ Set Screw Locking

Unit No.	Shaft Dia. Inch	Inch Parts - Dimensions (inch)							Basic Load Ratings lbf / N		Weight lbs
		D	Bi	Be	n	m	G	ds	Dynamic C	Static Co	
SSSB202-10	5/8	1.575	0.875	15/32	0.234	5/8	0.157	1/4 - 28UNF	1836	842	0.20
SSSB204-12	3/4	1.850	0.969	9/16	0.281	23/32	0.197	1/4 - 28UNF	2465	1241	0.29
SSSB205-16	1	2.047	1.063	19/32	0.295	49/64	0.216	1/4 - 28UNF	2678	1445	0.35
Unit No.	Shaft Dia. mm	Metric Parts - Dimensions (mm)							Basic Load Ratings lbf / N		Weight kg
		D	Bi	Be	n	m	G	ds	Dynamic C	Static Co	
SSSB204	20	47.0	24.6	14.3	7.1	18.3	5.0	M6x1.0	10957	5517	0.13
SSSB205	25	52.0	27.0	15.1	7.5	19.4	5.5	M6x1.0	11900	6426	0.16



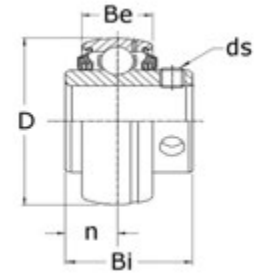

**TRIPLE LIP SEAL, BLACK OXIDE INSERT BEARINGS**  
**Wide Inner Ring Bearing**  
**UC 200 R3BO Series**

- ✓ Normal Duty
- ✓ Set Screw Locking

Unit No.	Shaft Dia. Inch	Inch Parts - Dimensions (inch)					Basic Load Ratings lbf / N		Weight lbs
		D	Bi	Be	n	ds	Dynamic C	Static Co	
UC205-16R3BO	1	2.047	1.344	21/32	0.563	1/4 - 28UNF	3150	1700	0.45
UC206-20R3BO	1-1/4S	2.441	1.500	3/4	0.625	1/4 - 28UNF	5770	2510	0.65
UC207-20R3BO	1-1/4	2.835	1.688	25/32	0.688	5/16 - 24UNF	5770	3450	1.15
UC207-22R3BO	1-3/8								1.05
UC207-23R3BO	1-7/16								0.95
UC208-24R3BO	1-1/2	3.150	1.938	13/16	0.750	5/16 - 24UNF	6500	3850	1.40
UC209-28R3BO	1-3/4	3.346	1.938	7/8	0.750	5/16 - 24UNF	7350	4100	1.50
UC210-31R3BO	1-15/16	3.543	2.031	15/16	0.750	3/8 - 24UNF	7900	4950	1.80
UC210-32R3BO	2S								1.70
UC211-32R3BO	2	3.937	2.188	31/32	0.875	3/8 - 24UNF	9750	5850	2.55

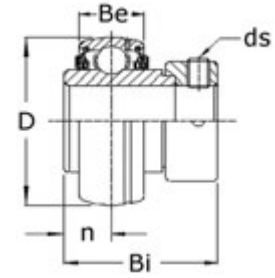

**TRIPLE LIP SEAL, BLACK OXIDE INSERT BEARINGS**  
**Wide Inner Ring Bearing**  
**HC 200 R3BO Series**

- ✓ Normal Duty
- ✓ Eccentric Collar Locking

Unit No.	Shaft Dia. Inch	Inch Parts - Dimensions (inch)					Basic Load Ratings lbf / N		Weight lbs
		D	Bi	Be	n	ds	Dynamic C	Static Co	
HC205-16R3BO	1	2.047	1.375	21/32	0.656	1/4 - 28UNF	3150	1700	0.51
HC206-20R3BO	1-1/4S	2.441	1.438	3/4	0.719	5/16 - 24UNF	4390	2510	0.80
HC207-20R3BO	1-1/4	2.835	1.484	25/32	0.750	5/16 - 24UNF	5770	3450	1.45
HC207-22R3BO	1-3/8								1.30
HC207-23R3BO	1-7/16								1.20
HC208-24R3BO	1-1/2	3.150	1.688	13/16	0.844	5/16 - 24UNF	6500	3850	1.75
HC209-28R3BO	1-3/4	3.346	1.688	7/8	0.844	5/16 - 24UNF	7350	4100	1.75
HC210-31R3BO	1-15/16	3.543	1.938	15/16	0.969	5/16 - 24UNF	7900	4690	2.25
HC210-32R3BO	2S								2.10

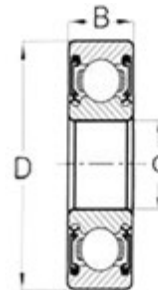

## 440C STAINLESS STEEL BALL BEARINGS

### Metric Size Bearings

### Miniature, 6000, 6200, 6300 Series

Part Number	Metric Parts - Dimensions (mm)		
	d	D	B
S608-2RS	8	22	7
S627-2RS	7	22	7
S688-2RS	8	16	5
S6000-2RS	10	26	8
S6001-2RS	12	28	8
S6002-2RS	15	32	9
S6003-2RS	17	35	10
S6004-2RS	20	42	12
S6005-2RS	25	47	12
S6006-2RS	30	55	13
S6007-2RS	35	62	14
S6008-2RS	40	68	15
S6009-2RS	45	85	16
S6200-2RS	10	30	9
S6201-2RS	12	32	10
S6202-2RS	15	35	11
S6203-2RS	17	40	12
S6204-2RS	20	47	14
S6205-2RS	25	52	15
S6206-2RS	30	62	16
S6207-2RS	35	72	17
S6208-2RS	40	80	18
S6209-2RS	45	85	19
S6210-2RS	50	90	20
S6300-2RS	10	35	11
S6303-2RS	15	47	14
S6304-2RS	20	52	15
S6305-2RS	25	62	17
S6306-2RS	30	72	19
S6307-2RS	35	80	21
S6308-2RS	40	90	23
S6309-2RS	45	100	25
S6904-2RS	20	37	9
S6905-2RS	25	42	9
S6910-2RS	50	72	12



## 440C STAINLESS STEEL BALL BEARINGS Inch Size Bearings R Series

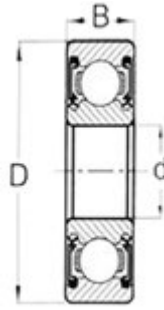

Part Number	Inch Parts - Dimensions (inch)		
	d	D	B
SR4-2RS	1/4	5/8	0.196
SR6-2RS	3/8	7/8	0.281
SR8-2RS	1/2	1-1/8	0.312
SR10-2RS	5/8	1-3/8	0.344
SR12-2RS	3/4	1-5/8	0.437
SR16-2RS	1	2	0.500
SR18-2RS	1-1/8	2-1/8	0.500
SR20-2RS	1-1/4	2-1/4	0.500
SR24-2RS	1-1/2	2-5/8	0.563

## 440C STAINLESS STEEL BALL BEARINGS Inch Size Bearings

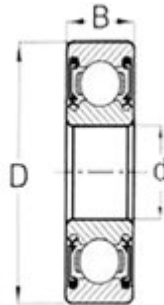

Part Number	Inch Parts - Dimensions (inch)		
	d	D	B
S1601-2RS	3/16	11/16	0.313
S1603-2RS	5/16	7/8	0.344
S1614-2RS	3/8	1-1/8	0.375
SK11621-2RS	1/2	1-3/8	0.438
S1640-2RS	7/8	2	0.563
SK11641-2RS	1	2	0.563



## ***KML K-Poly™ High Performance Solid Polymer Lubricant***

### **Solid Lubricated Bearings offer a true Lube-for-Life Solution! Maintenance-Free, Grease-Free Bearings**

If you need **FDA** approved lubricants, **K-Poly™ Food Grade Formula Solid Lubricated Bearings** are your answer. This engineered solid lubricant combines a micro-porous polymer with NSF registered H-1 food grade synthetic oils. The solid polymer encapsulates the oils while blocking out contaminants significantly extending bearing life. The polymer releases the correct amount of lubricating oil to the bearing while operating but does not leak or drip past the seals.

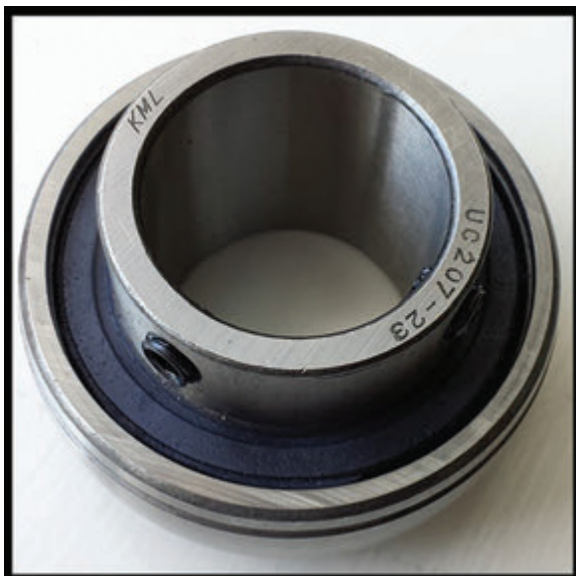

In many **KML** bearing styles the original seals and/or flingers are reinstalled after the solid lube is cured in the ball cavity. This extra sealing protection increases the service life of the bearing. It is not uncommon to double or triple the operating life of the bearing in the original application due to the superior performance of the solid lubricant coupled with labyrinth sealing systems.



# K-Poly™ H-1 Food Service Grade

**KML** K-Poly™ Solid Lubricant is a Micro-porous Polymer that is formulated with high performance synthetic lubricating oils, extreme pressure additives and corrosion inhibitors. The newest Perfluorinated Formula is effective in caustic extreme wash-down applications. The K-Poly™ micro structure releases the oil as the bearing warms to operating temperature. The oil is reabsorbed after the bearing stops operation, eliminating weeping and unwanted dripping. **KML** K-Poly™ is specially formulated with an NSF registered H-1 grade synthetic oil in Food Service and Sanitary applications.

## ***KML K-Poly™ H-1 Food Service Grade Solid Lubricant Part Number Suffix with Technical Information***

KML K-Poly Product Type	Food Grade Product Formula Description	Wash-Down Rated	Operating Temperature		Low Temp Viscosity Additive	Chemical Resistant	Steam Resistant	Color
			Low	High				
K-Poly FGCT	Food Service Grade H-1 Cryogenic Freezing Solid Lubricant	X	-65°F	275°F	X			White/Amber
K-Poly FGHT	Food Service Grade H-1 High Temperature Solid Lubricant	X	-25°F	350°F				White/Amber
K-Poly FGLT	Food Service Grade H-1 Low Temperature Solid Lubricant	X	-55°F	200°F	X			White
K-Poly FGPF	Food Service Grade H-1 Perfluorinated Solid Lubricant	X	-35°F	350°F		X	X	White

## ***KML K-Poly™ H-1 Food Service Grade Solid Lubricant provides solutions for difficult Sanitary Applications.***

- K-Poly™ Solid Polymer Lubricant eliminates the need to grease the bearing. It is a true Lube-for-Life option that can eliminate costly lubrication intervals or make central lubrication systems obsolete.
- K-Poly™ Solid Polymer Food Service Grade Lubricant meets H-1 criteria and is Sanitary Equipment Design compatible.
- K-Poly™ Polymer Solid Lubricant blocks out contaminants that can cause premature bearing failure.
- K-Poly™ retains oil in the solid polymer matrix eliminating the need for re-lubrication. The encapsulated synthetic oil prevents liquid weeping past the seals at temperature extremes.
- K-Poly™ reduces internal friction which reduces start-up torque even at low temperature conditions where normal lubrication becomes stiff or solidifies.
- K-Poly™ Low Temperature Performance to -65°F (-54°C) in Cryogenic applications.
- K-Poly™ Food Service Grade High Temperature Performance to 350°F (177°C).
- K-Poly™ Solid Polymer Lubricant eliminates unwanted grease purge which is a visual negative during inspection reviews.

# K-Poly™ Industrial Grade

**KML K-Poly™ Industrial Grade Solid Lubricant** is a Micro-porous Polymer that is formulated with high performance synthetic lubricating oils, extreme pressure additives and/or corrosion inhibitors. The K-Poly™ micro structure releases the oil as the bearing warms to operating temperature. The oil is reabsorbed after the bearing stops operation, eliminating weeping and unwanted dripping. **KML K-Poly™ Industrial Grade Solid Lubricant** is formulated for application specific requirements.

## **KML K-Poly™ Industrial Grade Solid Lubricant Part Number Suffix with Technical Information**

KML K-Poly Product Type	Industrial Formula Product Description	Wash- Down Rated	Operating Temperature		Extreme Pressure Additives	Low Friction Additive	Corrosion Inhibitors	Color
			Low	High				
K-Poly IGSL	Industrial Grade Solid Lubricant	X	-55°F	215°F	X	X	X	Gray
K-Poly IGHT	Industrial Grade High Temperature Range Solid Lubricant	X	-25°F	350°F	X	X		Gray
K-Poly IGOT	Industrial Grade Oven Temperature Range Solid Lubricant	X	-25°F	425°F	X	X		Gray

***KML K-Poly™ Industrial Grade Solid Lube is available in many bearing types and styles for the most demanding applications.***

- K-Poly™ Solid Polymer Lubricant eliminates the need to grease the bearing. It is a true Lube-for-Life option that can eliminate costly lubrication intervals or make central lubrication systems obsolete.
- K-Poly™ Polymer Solid Lubricant blocks out contaminants that can cause premature bearing failure.
- K-Poly™ retains oil in the solid polymer matrix eliminating the need for re-lubrication. The encapsulated synthetic oil prevents liquid weeping past the seals at temperature extremes.
- K-Poly™ Industrial Grade Solid Polymer Lubricant reduces internal friction which lowers start-up torque even at low temperature conditions where normal lubrication becomes stiff or solidifies.
- K-Poly™ Industrial Grade Solid Polymer Lubricant contains extreme pressure (EP) additives that reduce fretting and spalling under heavy loads.
- K-Poly™ Industrial Grade Solid Polymer Lubricant IGSL contains corrosion inhibitors to help prevent oxidation.
- **New!** K-Poly™ Industrial Grade Oven Temperature formula provides performance to 425°F (218°C) for bearings operating adjacent to fryers or baking equipment.



## KML Platinum Series

KML Bearing USA's FDA-H1 standard Corrosion Resistant Products feature Stainless Steel and Thermoplastic Mounted Bearing Units, Stainless Steel Radial Ball Bearings & Corrosion Resistant Insert Bearings.

### All Stainless Steel Insert Bearings

- Mobil FM222 Synthetic Food Grade Grease is NSF H1 registered for use in HACCP facilities.
- KML high frequency annealing process in the critical set screw area eliminates cracking.
- All housings are designed with smooth surfaces which are easily cleaned in wash-down applications.
- Stainless steel set screws have knurled-edge cup point design for positive shaft locking.

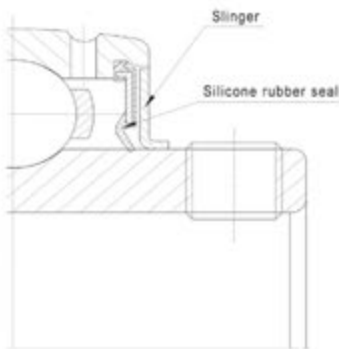

- The metal core silicone rubber seal snaps into a groove in the outer race for a secure fit.
- The stainless steel flinger creates a labyrinth barrier channel protecting the seal from direct wash-down exposure.
- Pillow blocks and tap base housings have solid base construction for secure mounting.
- 2, 3, and 4-bolt flanges have solid back face construction which reduces harborage sights and increases strength of the housing.

### Triple-Lip Black Oxide Insert Bearings

The triple lip rubber seal is mounted to a steel flinger guard. The flinger, when

crimped into the outer ring's seal groove, protects the seal lips from abrasive contaminants.

All three

lips contact the outside diameter surface of the ground inner ring. This configuration provides the best protection against contamination available on the market for these types of bearings.

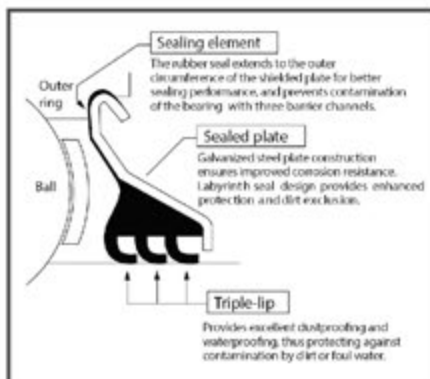

These seals are indicated by suffix R3 and are used on self-aligning bearings of UC type (set screw locking) and HC type (eccentric collar locking). To order these special UC and HC type bearings (when equipped with the triple lip seal and treated in black oxidation) please take note that the part number is followed by the suffix R3BO.



***KML Bearing USA***

213 Jones Boulevard  
Pottstown, PA 19464

Phone: 877.495.6134

Fax: 610.495.6183

[www.kmlbearingusa.com](http://www.kmlbearingusa.com)